

A

B

C

D

FRONT VIEW

REV	DESCRIPTION	DATE	APPROVAL

SIDE VIEW

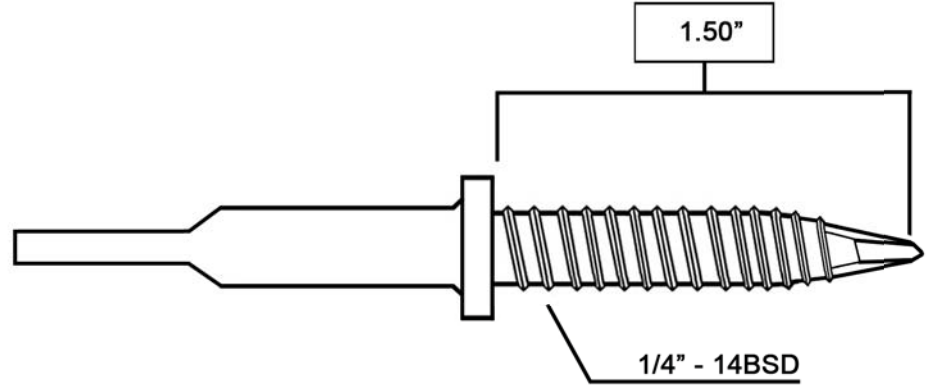
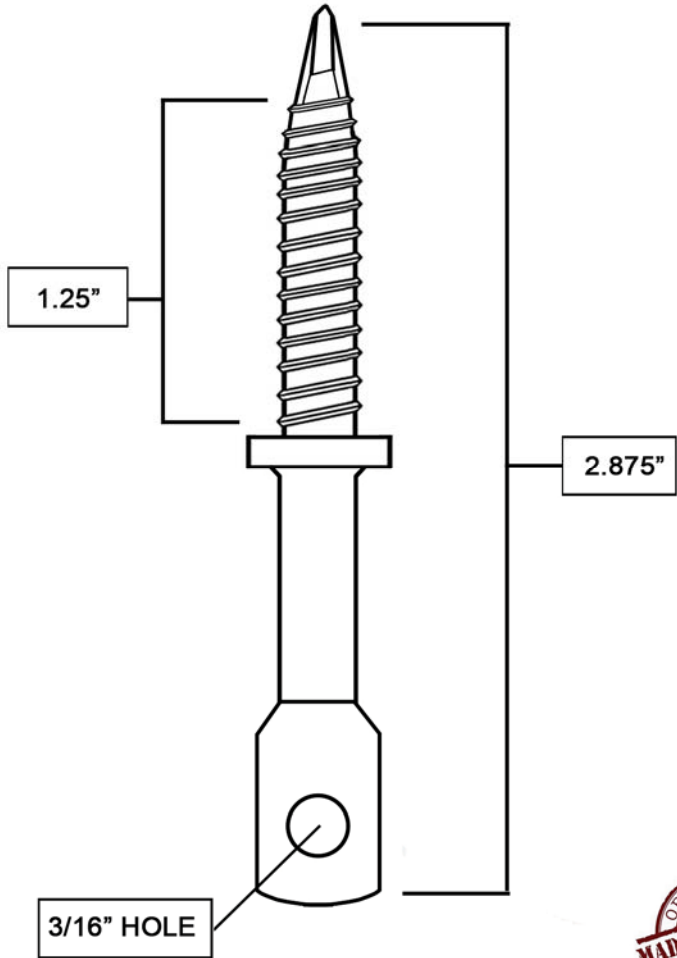

DOC'S
DOC'S INDUSTRIES, INC.

Title: **I-LAG™ 150PP**

Size: A	Scale: None	Part Number: 150PP	Rev:
-------------------	----------------	-----------------------	------

Date: 1/15/14 Drawn by: RO
Drawing Number: 0186 Sheet 1 of X

Notes: I-LAG™ Brand eye lag screw part # 150PP, Pinch point screw designed specifically for suspended ceiling applications only. Distributed by Doc's Industries, Inc. Simi Valley, CA 93063 (For tension applications only)

Material	CHQ 1022 STEEL
Finish	Electro-Galvanized Yellow Zinc Cr3+

Release Approval:	Tolerances: .X = +/- 0.02in .XX = +/- 0.01in .XXX = +/- .005in Unless Otherwise Specified
Release Date:	
Customer Approval:	Proprietary Rights: All information that is contained within is proprietary. Not for unauthorized use or disclosure.

A

B

C

D

1

2

3

4

1

2

3

4